



# EUROPEAN ANTENNAS

Excellence through design  
Creative in concept

## UNIVERSAL MOUNTING KIT

### MODEL: FPA19-15L MOUNTING KIT/112A

DESIGNED TO FIT 153B & 1352B ANTENNAS

**MOUNTING:** Pole, wall or ground

**MATERIAL:** Mild Steel Brkt. / St. Steel Fixings

**EL. ADJUSTMENT:** 0 - 90°

**FINISH:** Galvanised / Natural

**AZ. ADJUSTMENT:** Via rotation on pole / leg

**MASS:** 15 Kg / 33 lbs

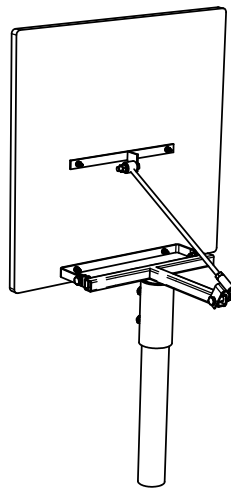
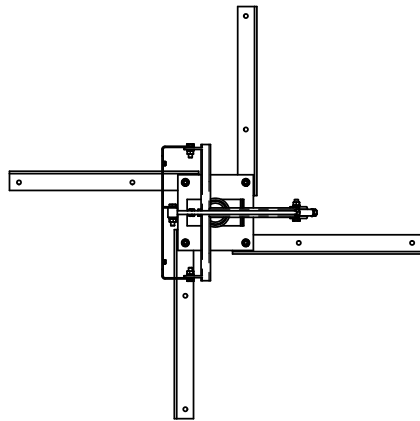

**POLE MOUNT**  
(MAXIMUM POLE SIZE = 65mm)

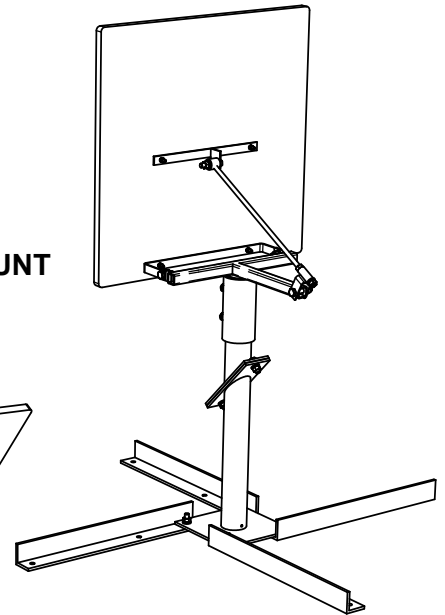

**GROUND MOUNT**

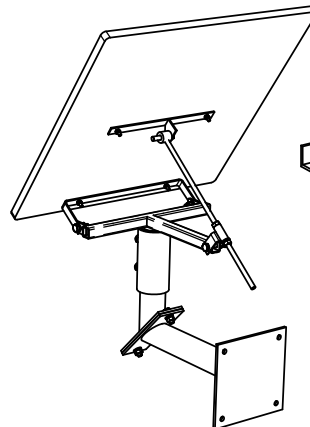
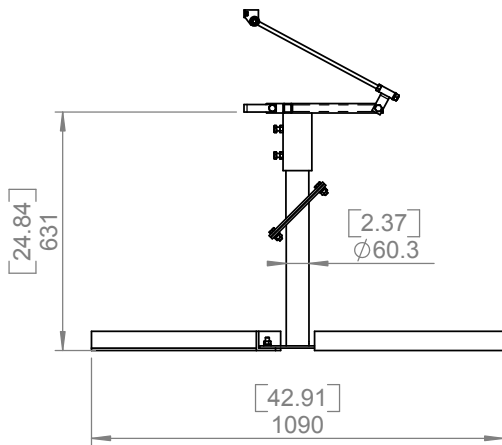

**WALL MOUNT**  
(NOTE: LIMITED ELEVATION ADJUSTMENT)

NOTE: ALL PICTORIAL VIEWS SHOWN WITH ANTENNA  
- SOLD SEPERATELY

DIMENSIONS: mm (inches) M  
GA: 112A - 1 Issued: 071106

EUROPEAN ANTENNAS LTD.

Tel: +44 (0)1638 731888  
Fax: +44 (0)1638 731999

LAMBDA HOUSE, CHEVELEY  
NEWMARKET, SUFFOLK, CB8 9RG,  
UNITED KINGDOM

E-Mail: sales@european-antennas.co.uk  
Website: www.european-antennas.co.uk

European Antennas Ltd. has a policy of continuous development and therefore stress that the data contained on this sheet should be used for guidance only.