



EUROPEAN ANTENNAS

Excellence through design
Creative in concept

FPA17-16RL BRACKET ASSEMBLY

MODEL: 056A

Mounting Kit for 1096B antenna, to be used in conjunction with Wall Mount 058A or Tripod Mount 066A

MATERIAL: Mild Steel

ELEVATION ADJUSTMENT: 0 - 180°

FINISH: Matt Black

AZIMUTH ADJUSTMENT: 0 - 180°

TOP VIEW

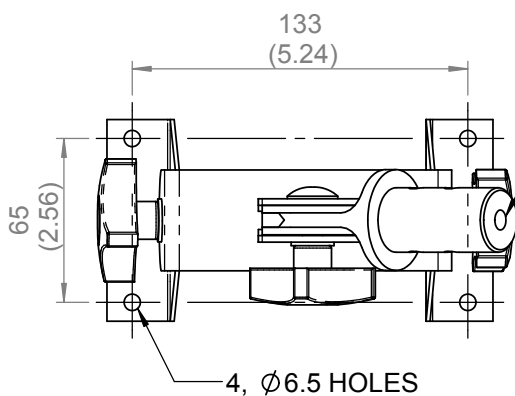

3/8 WHITWORTH THREAD
ALLOWING FITMENT ONTO
STANDARD CAMERA TRIPOD

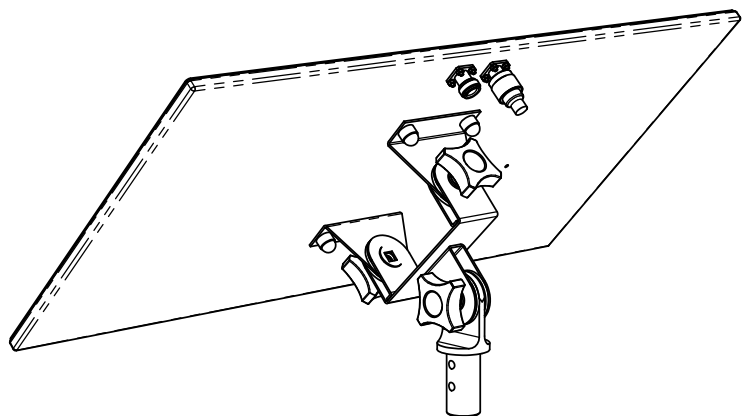

PICTORIAL VIEW (SHOWN MOUNTED TO 1096B ANTENNA)

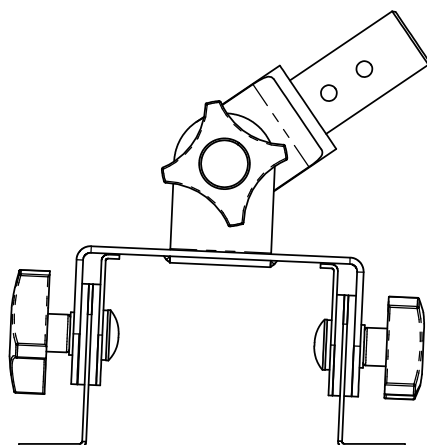

SIDE VIEW

| | |
|-------------------------|----------------|
| DIMENSIONS: mm (inches) | H |
| GA: 056A - 1 | Issued: 071204 |

EUROPEAN ANTENNAS LTD.

Tel: +44 (0)1638 731888
Fax: +44 (0)1638 731999

LAMBDA HOUSE, CHEVELEY
NEWMARKET, SUFFOLK, CB8 9RG,
UNITED KINGDOM

E-Mail: sales@european-antennas.co.uk
Website: www.european-antennas.co.uk