



# EUROPEAN ANTENNAS



## DUAL SECTOR ANTENNA

MODEL: DSA17-24V/466

FREQUENCY: 2.3 - 2.5 GHz	GAIN: 17 dBi
POLARISATION: Linear (Vertical)	BEAMWIDTH: 65° x 8°
CROSS POLAR: 20 dB	VSWR: 1.5 : 1
POWER RATING: 25 W	FRONT TO BACK: 30 dB
TEMPERATURE: -20°C to +50°C	MASS: 6.4 Kg/14.0 lbs
RADOME: Glass Fibre/Gloss White	WIND LOADING: 61.6Kg/135.6lbs@100mph

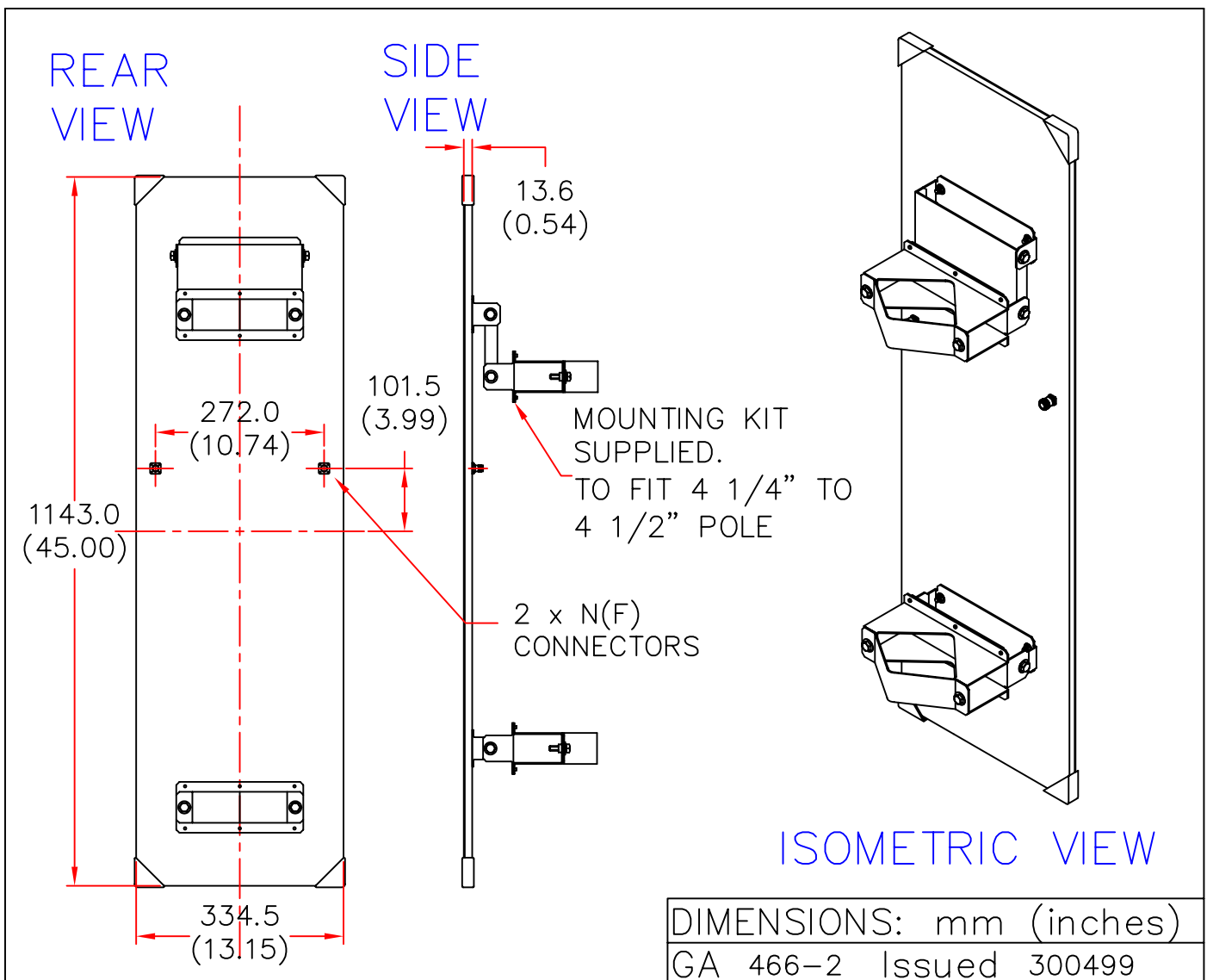

EUROPEAN ANTENNAS LTD.

TEL: +44 (0)1638 731888

LAMBDA HOUSE, CHEVELEY,  
NEWMARKET, SUFFOLK, CB8 9RG,  
UNITED KINGDOM.

FAX: +44 (0)1638 731999

European Antennas Ltd. has a policy of continuous development and therefore stress that the data contained on this sheet should be used for guidance only.