



EUROPEAN ANTENNAS

Excellence through design
Creative in concept

EXTENDED PERFORMANCE OMNI MOUNTING BRACKET

MODEL: MK039

MOUNTING BRACKET TO FIX XVO11-3500 ANTENNA TO 2-4" POLES

MATERIAL: 304L STAINLESS STEEL **FINISH:** N/A

GAUGE: 2.5mm **MASS:** Approx. 1.5 Kg

TOP VIEW

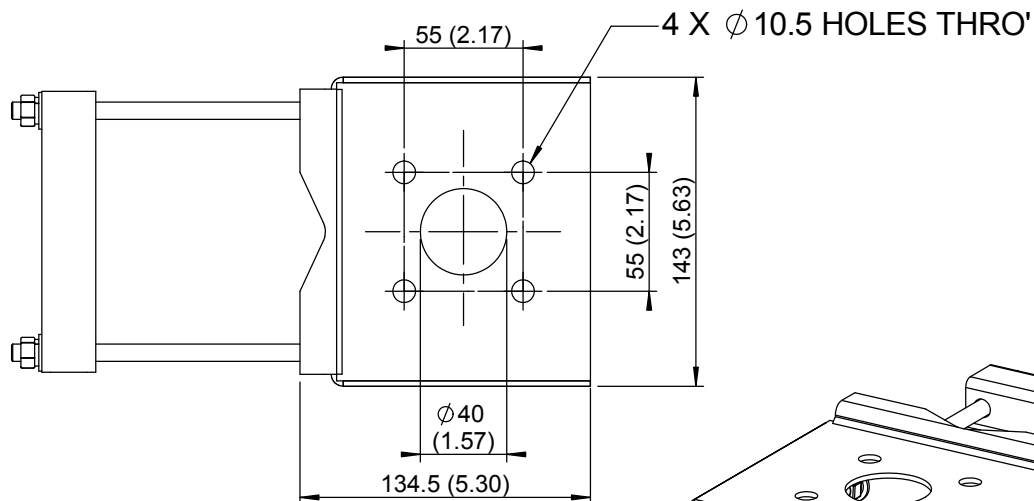

SIDE VIEW (HIDDEN DETAIL SHOWN)

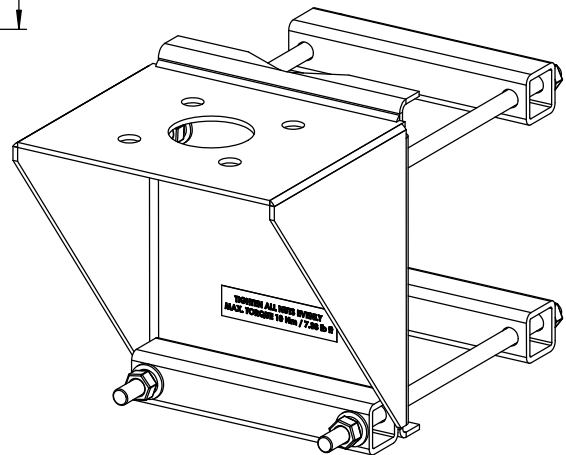
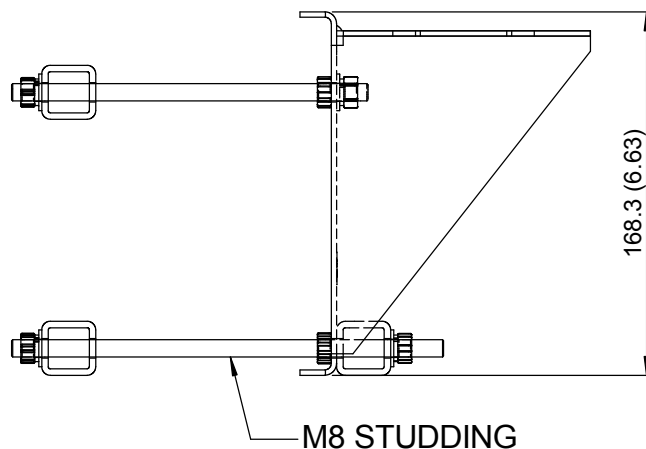

ISOMETRIC VIEW

DIMENSIONS: mm (inches)

GA:039A-2 Issued: 220501

EUROPEAN ANTENNAS LTD.

LAMBDA HOUSE, CHEVELEY
NEWMARKET, SUFFOLK, CB8 9RG,
UNITED KINGDOM

Tel: +44 (0)1638 731888
Fax: +44 (0)1638 731999

E-Mail: sales@european-antennas.co.uk
Website: www.european-antennas.co.uk