

OA2-960-1215V/2640

Blade Antenna

Key Features:

Designed for Link 16 military tactical data link network

Rugged and compact aerodynamic design

Ground plane dependent

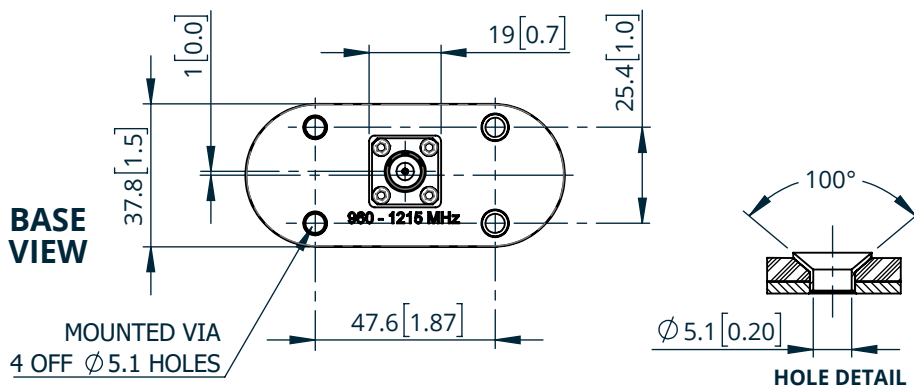
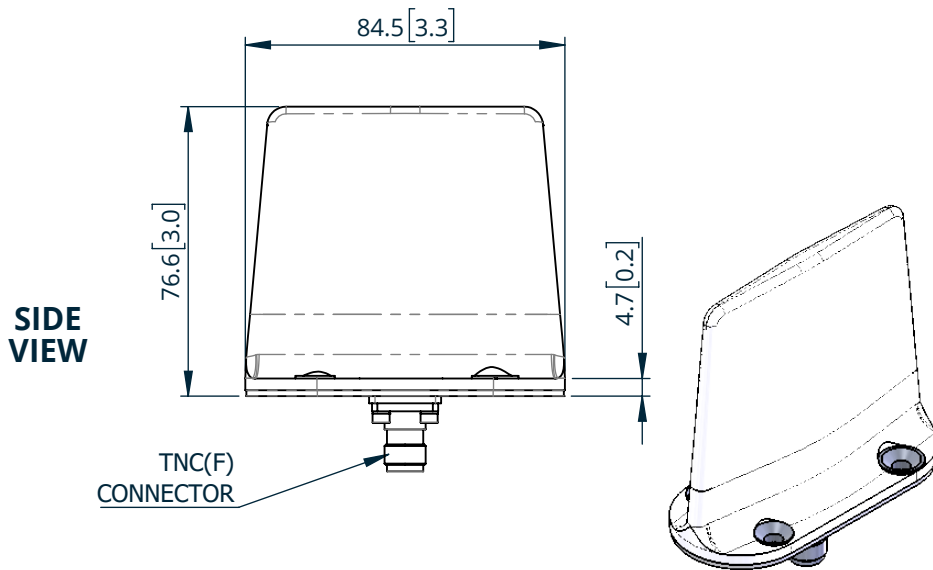
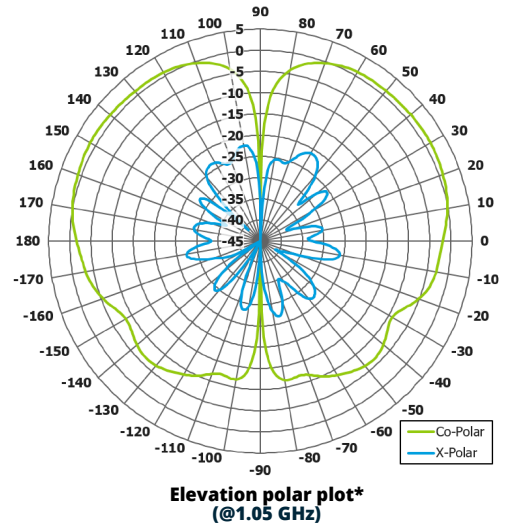
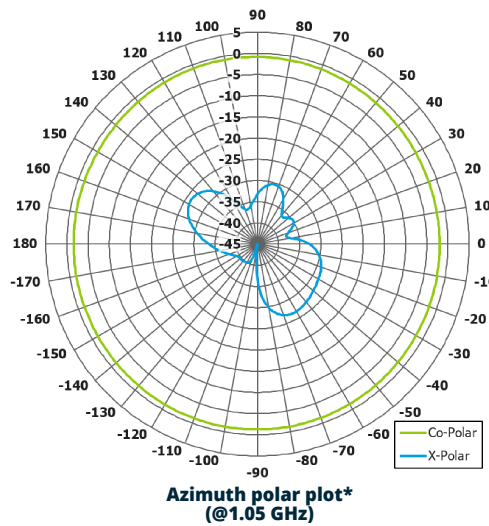

ELECTRICAL

Frequency: 960 to 1215 MHz

Gain: 3 dBi Typ. peak*

Polarisation: Vertical

Beamwidth: 360° x 60° Typ.

VSWR: 2:1 Typ, 2.5:1 Max.

Power Rating: 20 W

Electrical Tilt: 45° Typ.*

MECHANICAL

Standard Finish: White

Mass: 65 g / 2.3 oz

Temperature: -20 to +70°C

NOTES

* Measured on Ø500 ground plane.

Full radiation patterns and CAD available on request

DS: 2640-1

Issued: 030322

Dimensions: mm [inches]