



# EUROPEAN ANTENNAS

Excellence through design  
Creative in concept

## CYLINDRICAL WALL MOUNT FOR 1315B ANTENNA

### MODEL: T5 MKH/101A

<b>MOUNTING:</b>	Wall mount via screw holes	<b>MATERIAL:</b>	Aluminium
<b>EL. ADJUSTMENT:</b>	None	<b>FINISH:</b>	Powder Coat White RAL9016
<b>AZ. ADJUSTMENT:</b>	None	<b>MASS:</b>	215 g / 0.47 lbs

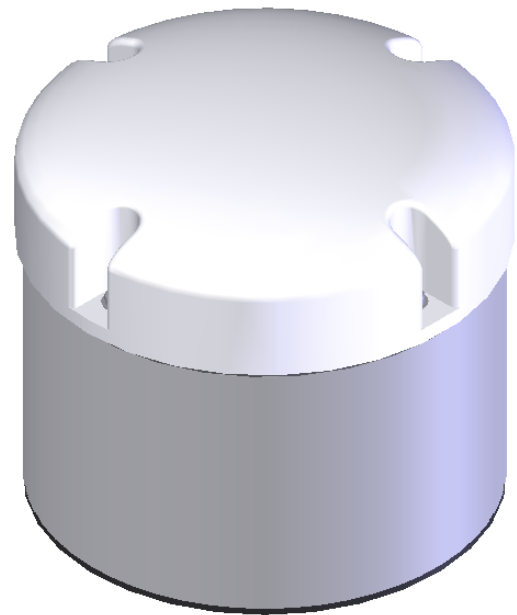
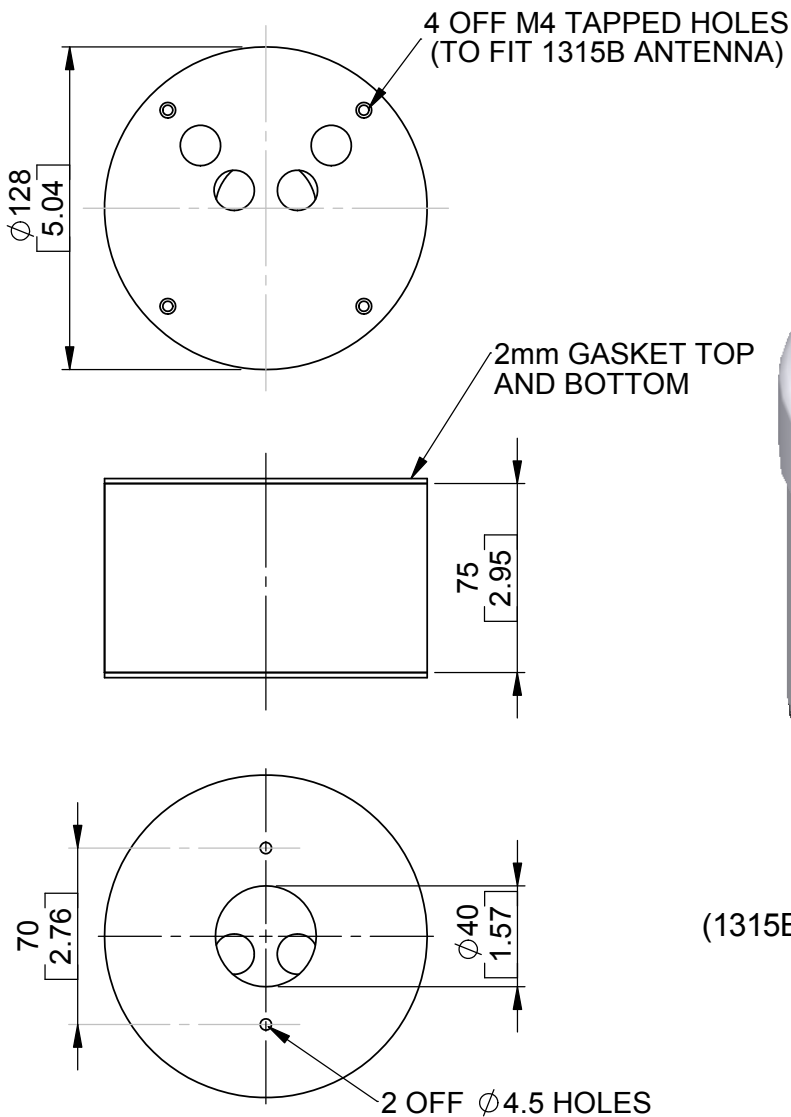

**PICTORIAL VIEW**  
(1315B ANTENNA SOLD SEPERATELY)

GA:101A-1 Issued: 120207 DIMENSIONS: mm [inches] M

EUROPEAN ANTENNAS LTD.  
LAMBDA HOUSE, CHEVELEY  
NEWMARKET, SUFFOLK, CB8 9RG,  
UNITED KINGDOM



Certificate No 9268

Tel: +44 (0)1638 731888  
Fax: +44 (0)1638 731999  
E-Mail: sales@european-antennas.co.uk  
Website: www.european-antennas.co.uk