

EVD2-47-TNC/1181

Rugged Dipole Antenna



Key Features

- Designed for Security Applications
- Suitable for Mobile Applications
- Compact
- Connector Options
- Ground Plane Independent

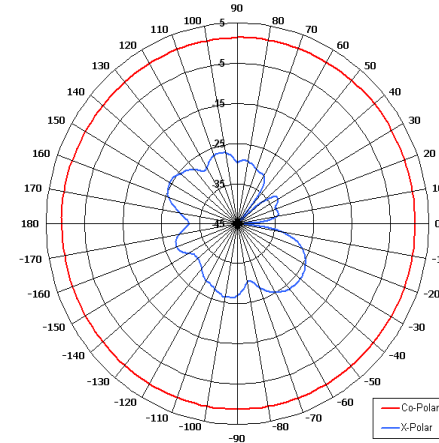

Azimuth Pattern

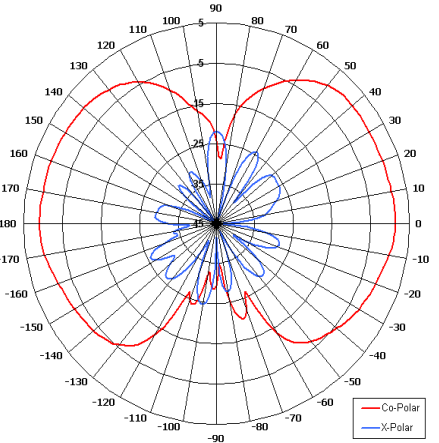

Elevation Pattern

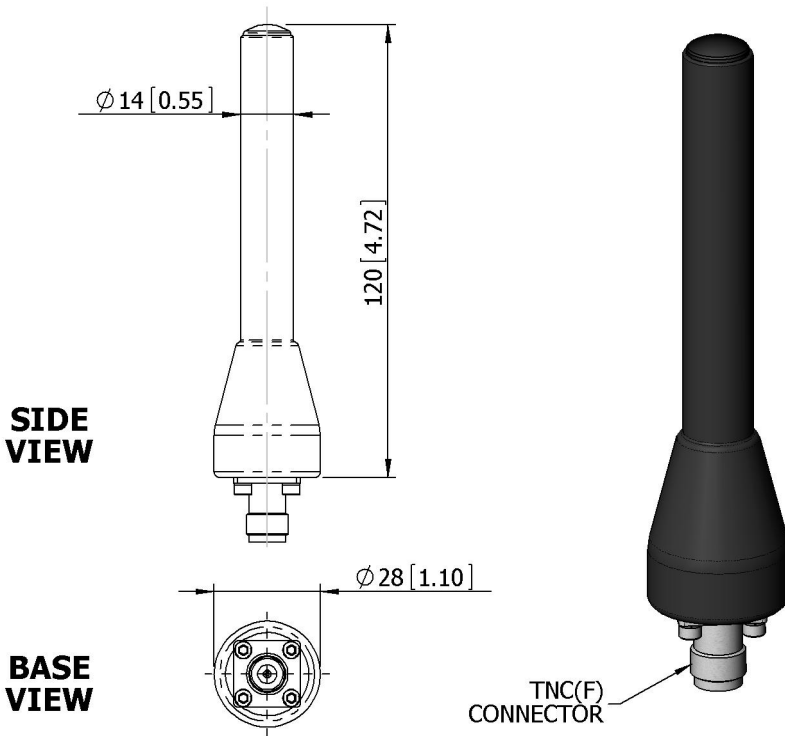

SIDE VIEW

BASE VIEW

GA: 1181

ELECTRICAL

Frequency	4.40 - 5.00 GHz
Gain	1.5 dBi Nom
Polarisation	Linear (Vertical)
Beamwidth	360° (Az) x 80° (El) Approx
Cross Polar	>20 dB Typ
VSWR	1.5:1
Power Rating	25W
Front to Back	N/A

MECHANICAL

Standard Finish	Matt Black
Mass	49g (1.73 oz) Approx
Temperature	-40° to +60°C
Wind Loading	N/A

MOUNTING OPTIONS

Kits Available	N/A
----------------	-----

See separate data sheets

ADDITIONAL NOTES

Issued 180210

Chelton Limited has a policy of continuous development and stress that the information provided is a guide only and does not constitute an offer or contract or part thereof. Whilst every effort is made to ensure the accuracy of the information contained in this brochure, no responsibility can be accepted for any errors or omissions.

The copyright of antenna designs and images is copyright protected and owned by Chelton Limited.
©Chelton Limited

For further information please contact:

Chelton Limited,
Lambda House, Cheveley,
Newmarket, Suffolk CB8 9RG, UK.
T: +44 (0)1638 732 177
E: newmarket.sales@chelton.com
W: www.chelton.com/microwave